

Динамические Системы



ЦЕНА и НАЛИЧИЕ

Насосы **VP/VCP**

Регулируемые пластинчатые
насосы

www.ds-gidro.ru

mag@ds-gidro.ru

8(800)201-67-88

一、产品简介

Products Introduction

VCP是一款新的改型变量叶片泵，通过引进国外高端技术，高精度智能和检测设备，产品结构更合理、性能更稳定，深获国内外客户的认同。

VCP系列变量叶片泵属限压式变量叶片泵，具有压力调整装置和流量调整装置。泵的输出流量可根据负载变化自动调节，使其输出功率与负载工作速度和负载大小相适应，具有高效、节能、安全可靠等特点，特别适用于作容积调速的液压系统中的动力源，如金属切削机床、压力机械、皮革机械、液压站等。

VCP is an improved type of variable vane pump, through the introduction of foreign high-end technology, high-precision intelligent and testing equipment, the product structure is more reasonable, more stable performance, deeply recognized by customers at home and abroad.

VCP Series variable Displacement vane pumps are the products with limiting pressure, equipped with both pressure and flow adjustment facilities. The outlet flow of the pump can regulate itself automatically according to the load, by which the outlet power and the working speed are in tune with the load. The pump is characterized by high efficiency, saving energy, safety and creditability and so on, and can be used in the hydraulic system for volumetric regulation, for instance, cutting machine tools, pressure and leather machinery, hydraulic station, and so on.

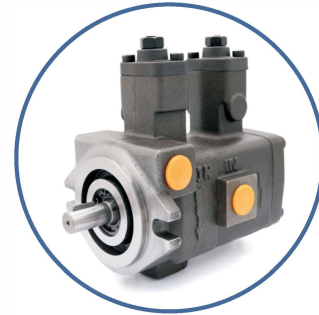

二、型号说明

Model Code

M—VCP ※—※ / ※—※ / ※—※—※

无标记-不带电动机
Unmarked- Without motor
M-带电动机
M-With motor

变量叶片泵
Variable vane pump

子系列代号1、2、11、22
Subsidiary series 1、2、11、22

单泵或双泵的轴端泵流量
Outlet flow of single or shaft end pump L/min

单泵或双泵的轴端泵压力调整范围
Operating pressure range of single pump or double pump shaft end pump:

20:	1.0-2.0MPa
35:	1.5-3.5MPa
55:	3.0-5.5MPa
70:	5.0-7.0MPa

驱动功率
Input power kW
带电机时标注
Marking with motor

轴伸形式: 1—平键轴
2—花键轴
Form of shaft: 1—Str. Key shaft
2—Spline shaft

双泵的盖端泵压力调整范围
Operating pressure range of cover end pump:

20:	1.0-2.0MPa
35:	1.5-3.5MPa
55:	3.0-5.5MPa
70:	5.0-7.0MPa

双泵的盖端泵流量
Outlet flow of cover end pump L/min

三、技术规格

Specifications

单泵 Single Pump

型号 Model	最大流量 Outlet flow L/min at 0.35MPa and 1800 r/min	压力调整 Operating pressure range Mpa	转速范围 Range of speed r/min	旋转方向(从轴端看) Direction of rotation (Viewed from shaft end)	质量 Weight kg
VCP1-8-20	8	1.0—2.0	800—1800	顺时针 Clockwise	5
VCP1-8-35		1.5—3.5			
VCP1-8-55		3.0—5.5			
VCP1-8-70		5.0—7.0			
VCP1-12-20	12	1.0—2.0			
VCP1-12-35		1.5—3.5			
VCP1-12-55		3.0—5.5			
VCP1-12-70		5.0—7.0			
VCP1-15-20	15	1.0—2.0			
VCP1-15-35		1.5—3.5			
VCP1-15-55		3.0—5.5			
VCP1-15-70		5.0—7.0			
VCP1-20-20	20	1.0—2.0			
VCP1-20-35		1.5—3.5			
VCP1-20-55		3.0—5.5			
VCP1-20-70		5.0—7.0			
VCP2-30-20	30	1.0—2.0	800—1800	顺时针 Clockwise	9
VCP2-30-35		1.5—3.5			
VCP2-30-55		3.0—5.5			
VCP2-30-70		5.0—7.0			
VCP2-40-20	40	1.0—2.0			
VCP2-40-35		1.5—3.5			
VCP2-40-55		3.0—5.5			
VCP2-40-70		5.0—7.0			

双联泵 Double Pumps

型号 Model	轴端泵流量 Outlet flow of shaft end pump	盖端泵流量 Outlet flow of cover end pump
VCP11	8、12、15、20	8、12、15、20
VCP22	30、40	30、40

单泵 Single Pump

VCP1(1-平键轴 Str. Key shaft)

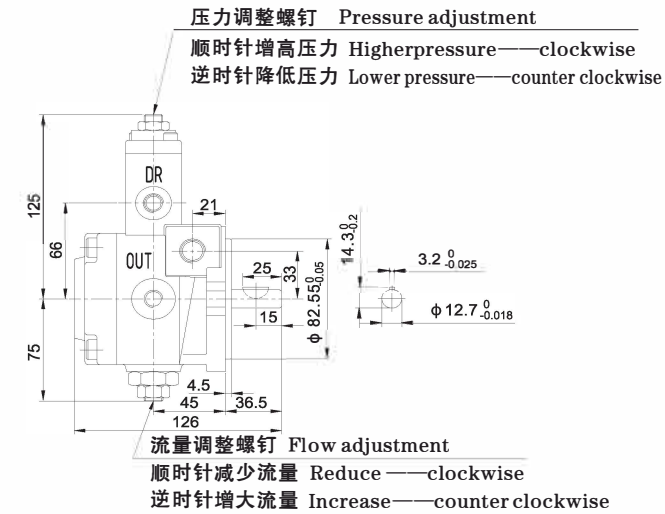

四、安装联接尺寸

Install Connection Dimensions

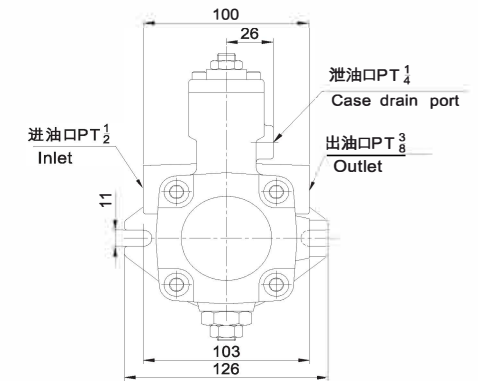

VCP1(2-花键轴 Spline shaft)

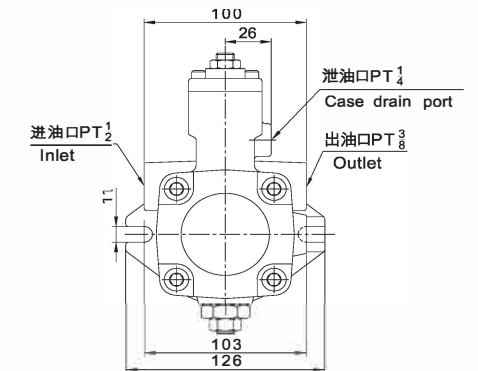
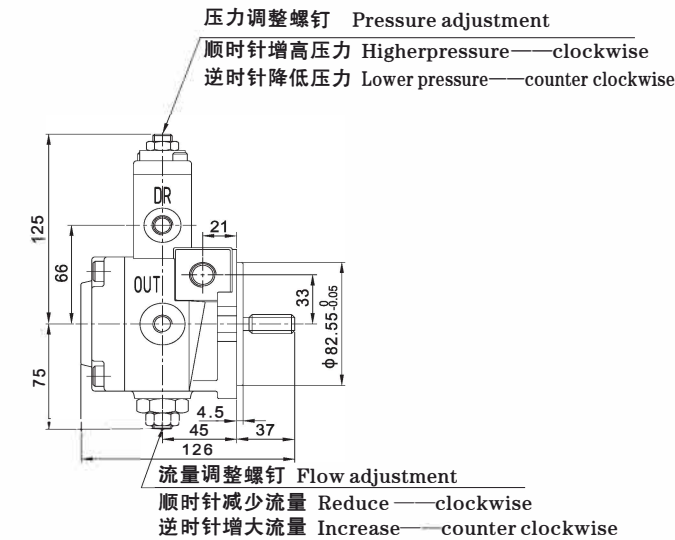

依美国ANSI B92.1规范

According to the US ANSI B92.1 specifications

精度等级: 5级

Class of accuracy: class 5

模数	Module	D.P.16/32
压力角	Pressure Angle	30°
齿数	Number of Teeth	9
节圆直径	Pitch Diameter	$\phi 14.2875$
最大直径	Maximum Diameter	$\phi 15.875_{-0.05}$
最小直径	Minimum Diameter	$\phi 11.811(\text{max})$

VCP2(1-平键轴Str. Key shaft)

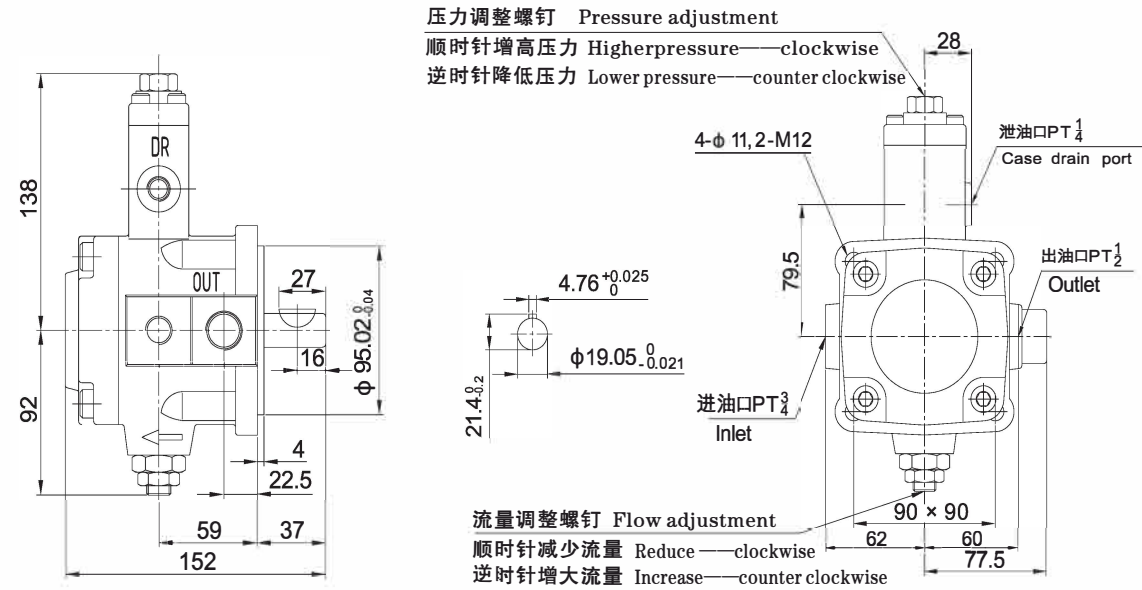

VCP2(2-花键轴Spline shaft)

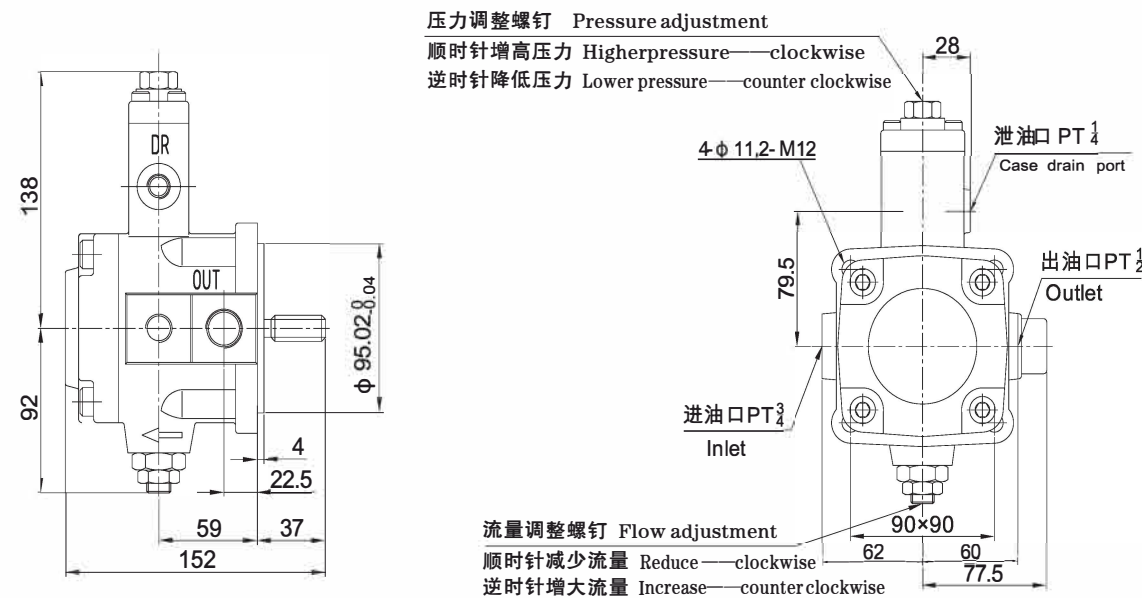

依美国ANSI B92.1规范

精度等级: 5级

According to the US ANSI B92.1 specifications

Class of accuracy: class 5

模数	Module	D.P.16/32
压力角	Pressure Angle	30°
齿数	Number of Teeth	9
节圆直径	Pitch Diameter	φ14.2875
最大直径	Maximum Diameter	φ15.875 ⁰ _{-0.05}
最小直径	Minimum Diameter	φ11.811(max)

双联泵 Double Pumps

VCP11(1-平键轴Str. Key shaft)

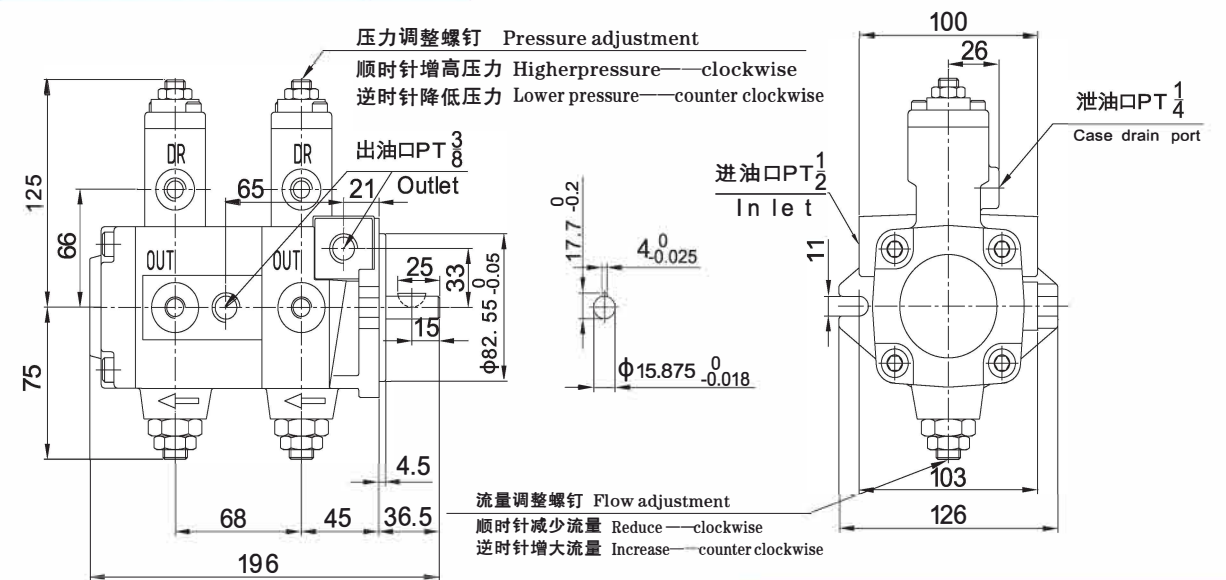

VCP11(2-花键轴Spline shaft)

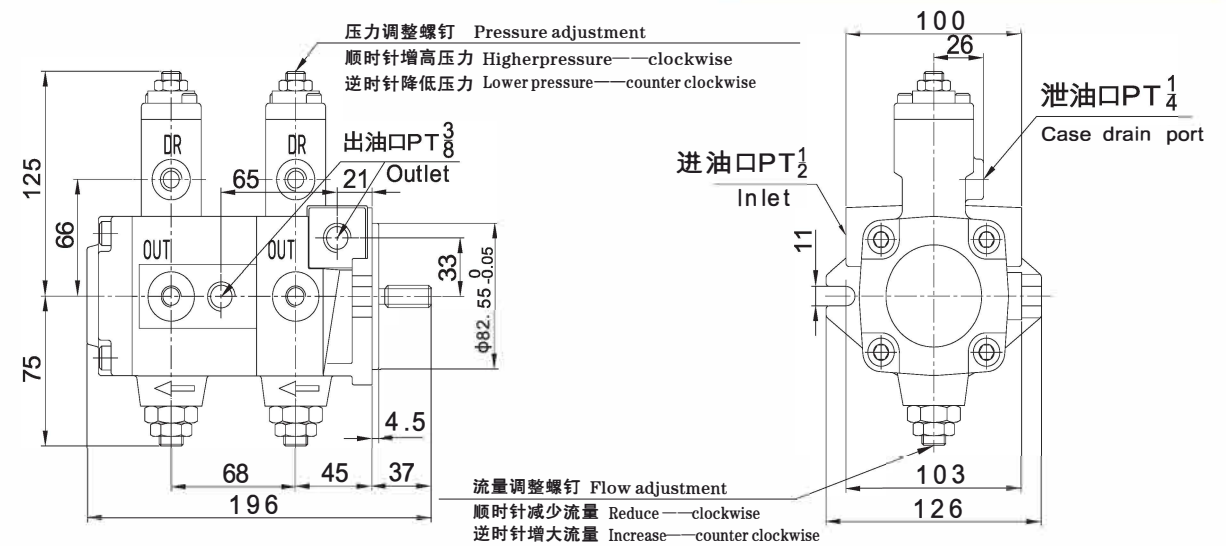

依美国ANSI B92.1规范

精度等级: 5级

According to the US ANSI B92.1 specifications

Class of accuracy: class 5

模数	Module	D.P.16/32
压力角	Pressure Angle	30°
齿数	Number of Teeth	9
节圆直径	Pitch Diameter	φ14.2875
最大直径	Maximum Diameter	φ15.875 ⁰ _{-0.05}
最小直径	Minimum Diameter	φ11.811(max)

VCP22 (1-平键轴 Str. Key shaft)

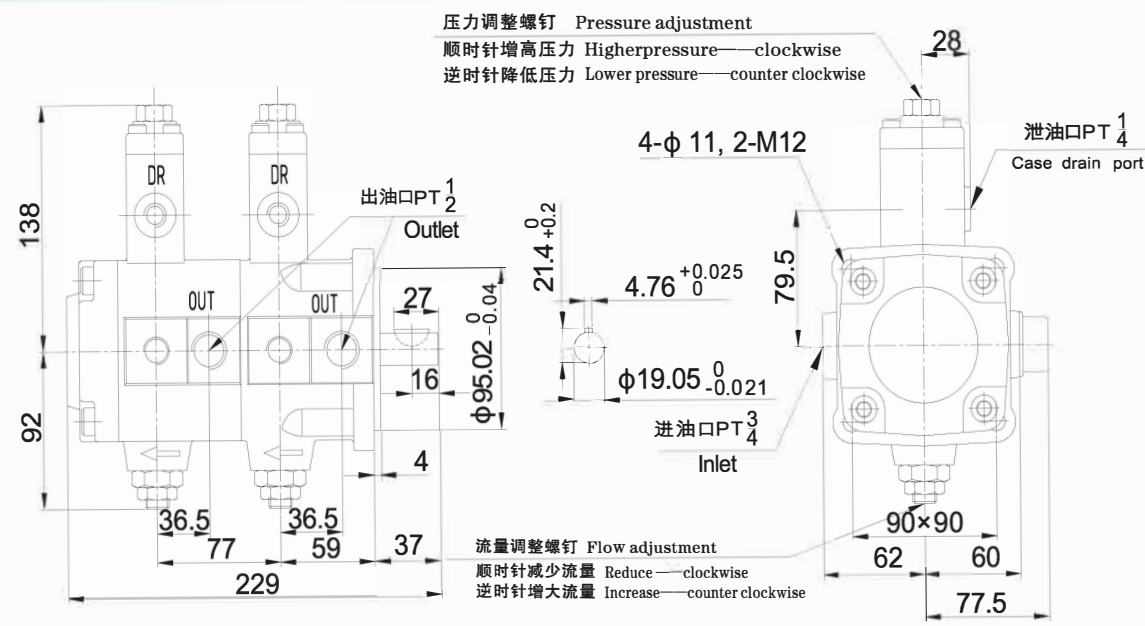

VCP22(2-花键轴 Spline shaft)

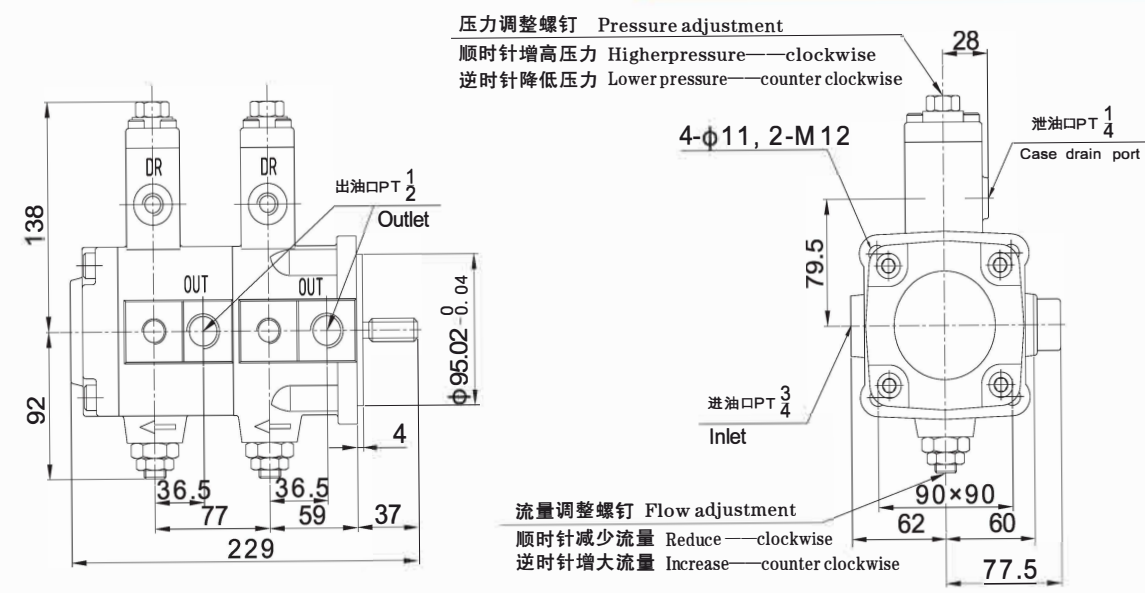

依美国ANSI B92.1规范

精度等级: 5级

According to the US ANSI B92.1 specifications

Class of accuracy: class 5

模数	Module	D.P. 16/32
压力角	Pressure Angle	30°
齿数	Number of Teeth	9
节圆直径	Pitch Diameter	φ14.2875
最大直径	Maximum Diameter	φ15.875 ±0.05
最小直径	Minimum Diameter	φ11.811(max)

M - VCP1

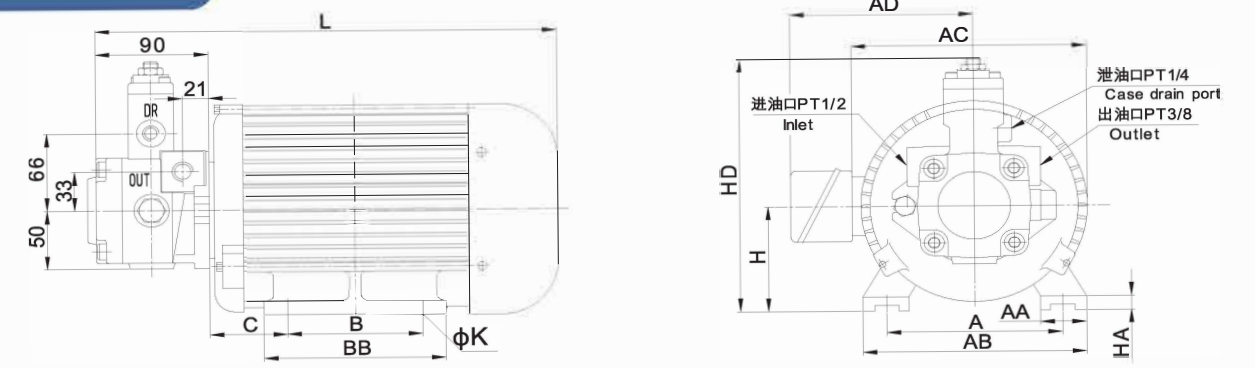

流量 L/min Outlet flow	压力 MPa Pressure	驱动功率 kW Input power	A	AA	AB	AC	AD	B	BB	C	H	HA	HD	K	L
12	3.5	0.75	125	35	155	177	140	100	130	53.5	80	10	207	10	330
	5.5	0.75	125	35	155	177	140	100	130	53.5	80	10	207	10	330
	7.0	1.50	140	35	170	196	160	125	150	57	90	10	217	12	368
15	3.5	0.75	125	35	155	177	140	100	130	53.5	80	10	207	10	330
	5.5	1.50	140	35	170	196	160	125	150	57	90	10	217	12	368
	7.0	1.50	140	35	170	196	160	125	150	57	90	10	217	12	368
20	3.5	0.75	125	35	155	177	140	100	130	53.5	80	10	207	10	330
	5.5	1.50	140	35	170	196	160	125	150	57	90	10	217	12	368
	7.0	1.50	140	35	170	196	160	125	150	57	90	10	217	12	368

M - VCP2

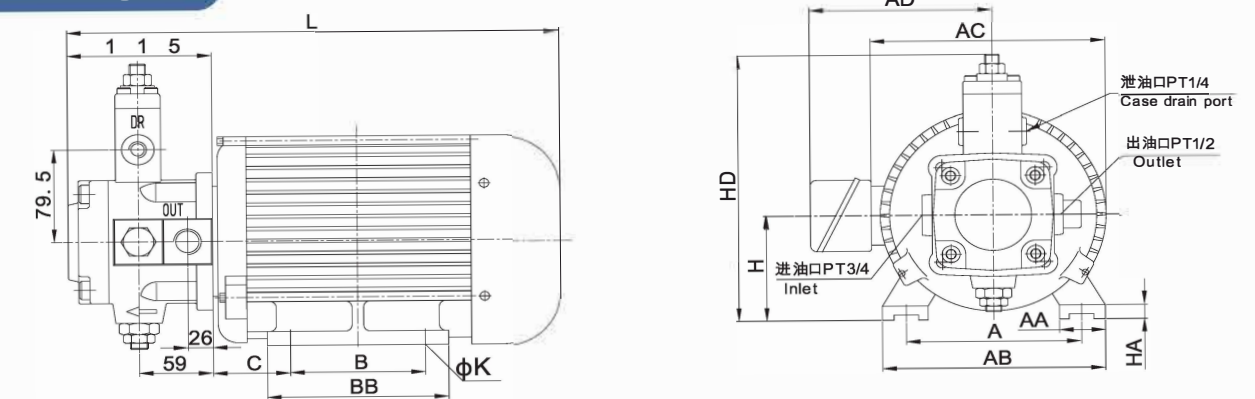

流量 L/min Outlet flow	压力 MPa Pressure	驱动功率 kW Input power	A	AA	AB	AC	AD	B	BB	C	H	HA	HD	K	L
30	3.5	1.5	140	35	170	196	160	125	150	57	90	10	238	12	393
	5.5	2.25	160	45	200	225	160	140	175	65	100	12	248	12	422
	7.0	3.75	190	45	228	245	180	140	175	73.5	112	12	260	12	445
40	3.5	1.5	140	35	170	196	160	125	150	57	90	10	238	12	393
	5.5	3.75	190	45	228	245	180	140	175	73.5	112	12	260	12	445
	7.0	5.5	216	45	250	270	190	140	175	77	132	16	280	12	450

五、特性曲线

Characteristic Curves

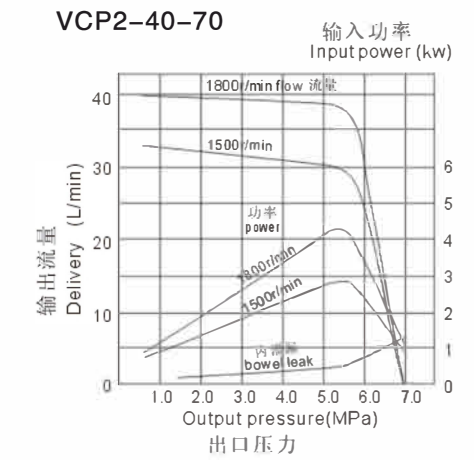
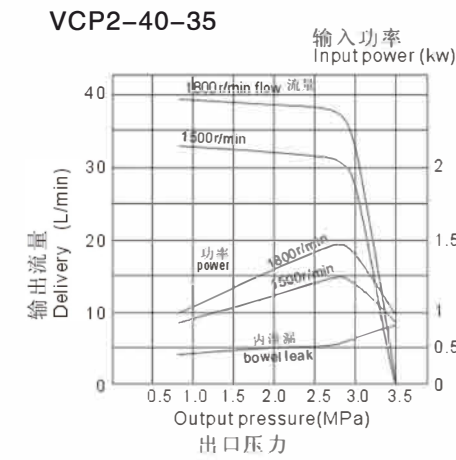
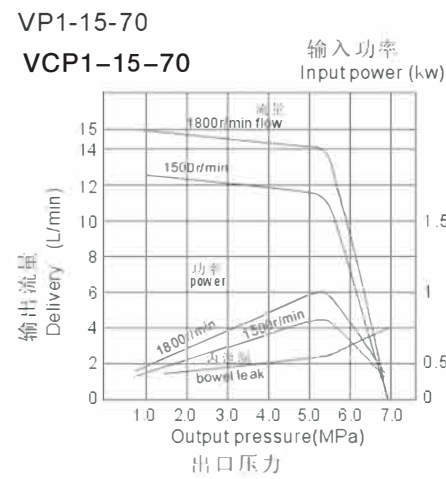
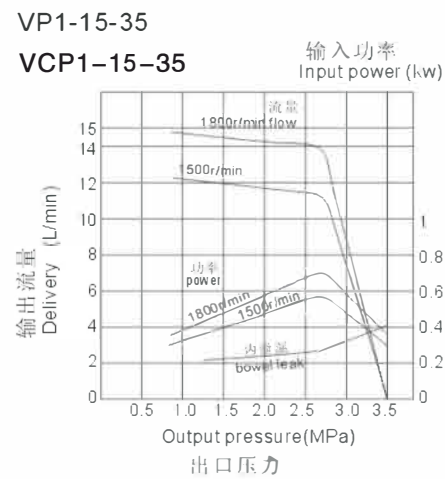
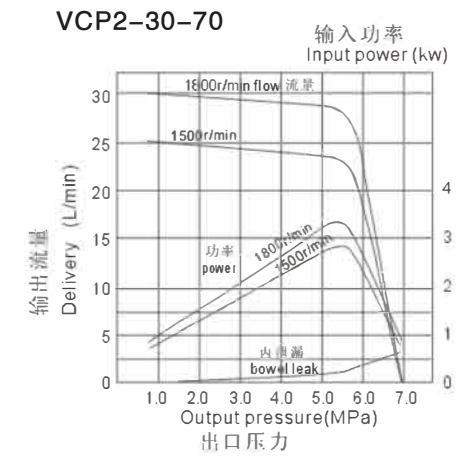
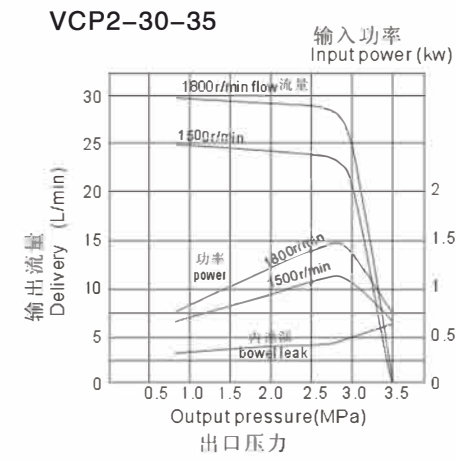
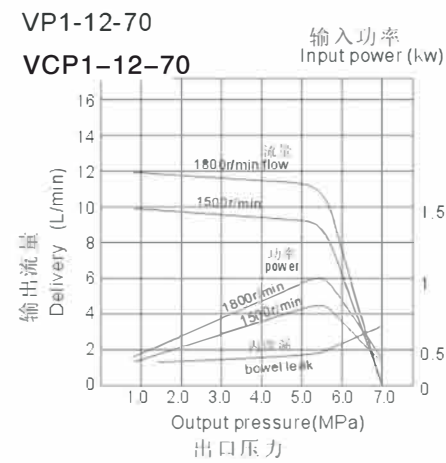
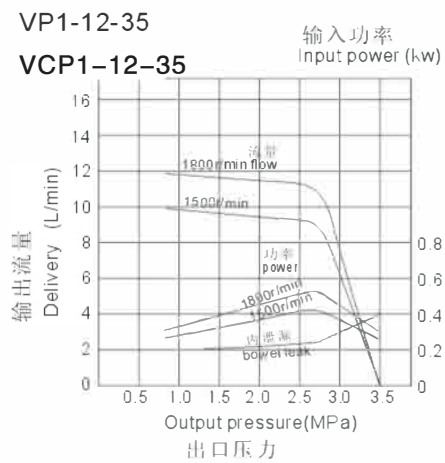
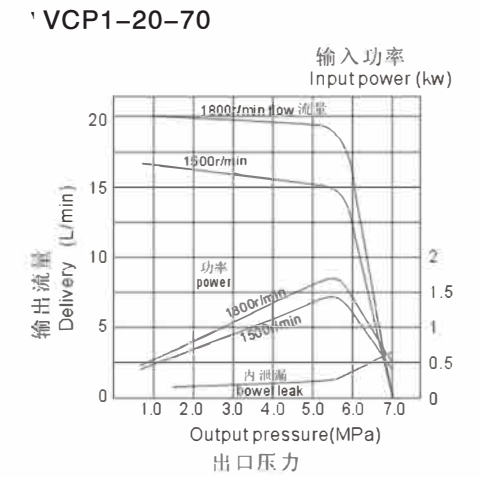
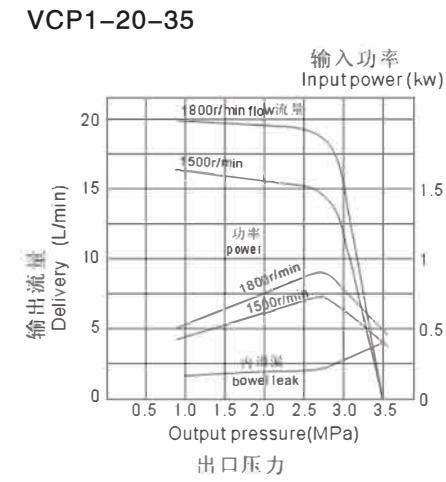
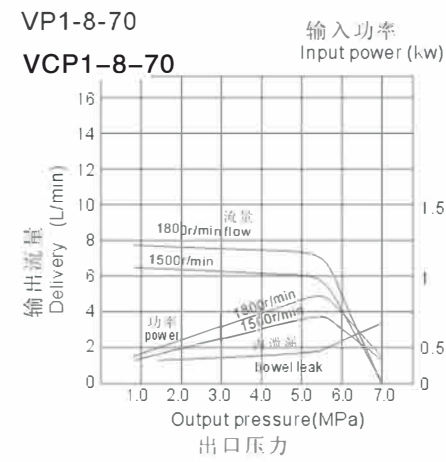
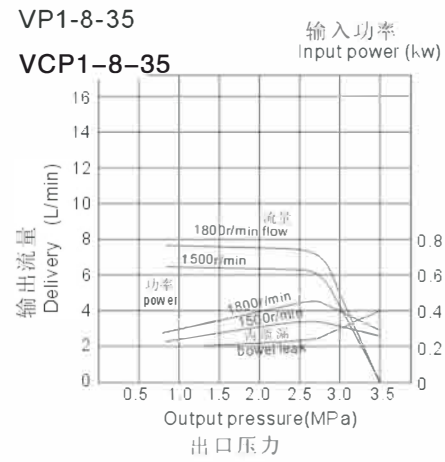

六、安装使用

Installation and Use

1. 泵的转向从轴端看为右转（顺时针方向）。
2. 泵轴要水平安装。泵轴与电机轴的偏芯误差在0.05mm以内，角度误差为1°以内。轴端应避免增加径向和轴向负荷。同时应选用有足够刚性材料作为安装台架。
3. 按泵的油口尺寸配接管径，特别是进油管。进油管路要严格密封，不得漏气；系统应设有冷却装置（如无冷却装置，则应加大油箱容积）；油箱应设有隔板，用来分隔回油带来的气泡与脏物；回油管口应低于液面，浸入油液的最小深度为50mm，即使在较低的允许液面高度时也是如此，以避免形成泡沫；泵的吸入口压力为-0.03~+0.03MPa；当泵安装在油箱液面以上时，推荐吸入口离油液液面高度小于500mm。
4. 泄油管务必直接连接到油箱油面下，配管阻力应在0.03MPa以下。
5. 出厂时P-Q的设定：
 - 流量设定=产品样本的指定型号设定的最大流量；
 - 压力设定=压力调整范围的最小值。
6. 流量与压力调整：

调整流量与压力时，先松开锁紧螺母，再旋转调整螺钉；调整完毕，拧紧锁紧螺母。

 - 顺时针旋转流量调整螺钉，流量减少；逆时针旋转，流量增加。
 - 顺时针旋转压力调整螺钉，压力增加；逆时针旋转，压力减少。
7. 止推螺栓：

止推螺栓在泵组装时已设定好，请不要调整。
8. 液压油：
 - 请使用40℃时粘度为30~50cSt(ISO VG32)的液压油。
 - 液压油温度范围为15~60℃。初始油温在15℃以下时，请用低压预运行使油温达到15℃。
9. 保持油液清洁，管路和油箱必须彻底洗净；系统中应安装精过滤器，建议为25μm，油液精度等级应在NSA10级以内；同时，应在泵吸入口端安装足够容量的滤油器（其额定通流量应大于泵流量的两倍），建议精度为100μm（150目），滤油器距油箱底部应大于50mm。
10. 为保证泵滑动面充分润滑，运行前请向泵体内注油。
11. 初次使用：请在无负载状况下先行反复启动马达，以排出泵内和油管内的空气。当确认油泵排出油后，为确保排除系统中所含的空气，最好继续无负荷运转10分钟。对于排气困难的管道，请安装排气阀。

1. Clockwise rotation viewed from shaft end is standard.
2. The pump shaft must be horizontally installed. For proper alignment of pump and electric motor shaft, the eccentricity between them must be kept within 0.05mm and the eccentric angle error between them must be kept within 1°. The shaft ends avoid increasing radial and axial loads. In addition, please use sufficient rigid material as the mounting bracket.
3. Fix pipes, especially inlet pipes, in accordance with the size of port; Inlet pipes must be strictly sealed with no leakage; System should be equipped with cooling device (without cooling unit, should increase fuel tank volume); The fuel tank shall be equipped with a diaphragm to separate the bubbles and dirt from the oil; The oil return nozzle should be lower the fluid surface, the minimum depth of 50mm, even in a low, too, when the permissible level of to avoid the formation of bubbles; Inlet port pressure should be -0.03 to +0.03MPa; In case where the pump is installed on the tank or at the position higher than the tank top cover, the height of the suction port of the pump should be less than 500mm.
4. Drain connection must be piped directly to tank and below the oil level with a back pressure not exceed 0.03MPa.
5. The setting value of P-Q at the factory:
 - Flow setting: The max. flow as catalogue shown.
 - Pressure setting: The min. operating pressure range.
6. Flow and pressure adjustment:

For adjusting them, first loosen the tightly locked nut, and then spin screws, After adjustment, tighten the lock nut.

 - The flow will be reduced when the flow adjusting screw is turned clockwise and increased when anti-clockwise.
 - The pressure will be increased when the pressure adjusting screw is turned clockwise and reduced when anti-clockwise.
7. Thrust bolt:

The thrust bolts are set when the pump is assembled, Please do not adjust.
8. Hydraulic oil:
 - Use the hydraulic oil of 30 ~ 50cSt (ISO VG32) at 40℃.
 - The hydraulic oil temperature range of 15 ~ 60 °C. Initial oil temperature below 15 °C, please use the low voltage operation to oil temperature 15 °C.
9. Oil should be kept clean, pipes and tanks must be thoroughly cleaned. Precise filters should be

assembled with the advised precision of 25 μ m in the system, the cleanness level of oil should be within NSA10; Fix the sufficient-volume filter (the rated flow rate should be greater than twice the pumpflow)at the inlet of the pump 50mm above the bottom of the tank, with the suggested precision of 100 μ m(150 mesh).

10. To ensure adequate lubrication of the pump sliding surface, please fill the pump body before running.

11. First use :Start up the pump under No-Load condition and repeat to start and stop the motor several times to extract the air from inside of the pump and piping. Then keep a 10 minutes continuous running for a better de-airing. For exhaust pipes, install an exhaust valve.